

EXPERIMENTS

EXPERIMENT 1

AIM

To determine resistance per unit length of a given wire by plotting a graph of potential difference versus current.

APPARATUS AND MATERIAL REQUIRED

A wire of unknown resistance ($\sim 10\Omega$), battery eliminator or an accumulator (0 to 3V) or two dry cells (1.5 V each), voltmeter (0-5 V), milliammeter (0-500 mA), rheostat, plug key, connecting wires and a piece of sand paper.

PRINCIPLE

Ohm's law states that the electric current flowing through a conductor is directly proportional to the potential difference across its ends, provided the physical state of the conductor remains unchanged.

If I be the current flowing through the conductor and V the potential difference across its ends, then according to Ohm's law

$$V \propto I$$

and hence

$$V = RI$$

(E 1.1)

where R is the constant of proportionality and is termed as the electrical resistance of the conductor. If V is expressed in volts and I in amperes, then R is expressed in ohms. The resistance R , depends upon the material and dimensions of the conductor. For a wire of uniform cross-section, the resistance depends on the length l and the area of cross-section A . It also depends on the temperature of the conductor. At a given temperature the resistance

$$R = \frac{l}{A}$$

(E 1.2)

where ρ is the specific resistance or resistivity and is characteristic of the material of wire.

Combining Eqs. (E 1.1) and (E 1.2) we have

$$(E 1.3) \quad V = \frac{l}{A} I$$

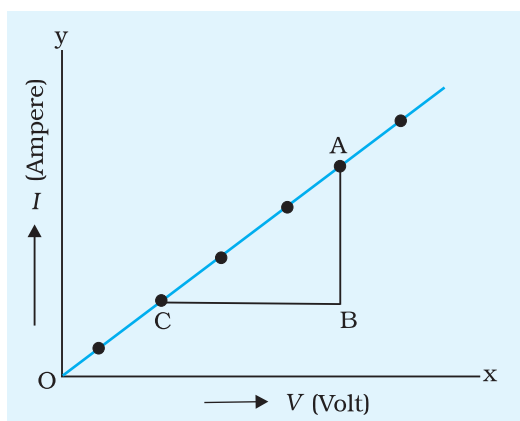

Fig. E 1.1 Graph between current I and potential difference, V

A linear relationship is obtained between V and I , i.e. the graph between V and I will be a straight line passing through the origin as shown in Fig. E 1.1. The slope of the graph is $1/R$ from Eq. (E 1.1) (Equation of straight line passing through origin is $y = mx$ where m is the slope of graph).

$$\text{Slope} = \frac{1}{R}$$

$$\Rightarrow R = \frac{1}{\text{slope}}$$

If l is the length of wire then the resistance per unit length of the wire $\frac{R}{l}$.

PROCEDURE

1. Clean the ends of the connecting wires with the help of sand paper in order to remove any insulating coating on them.
2. Connect various components - resistance, rheostat, battery, key, voltmeter and ammeter as shown in Fig. E 1.2.

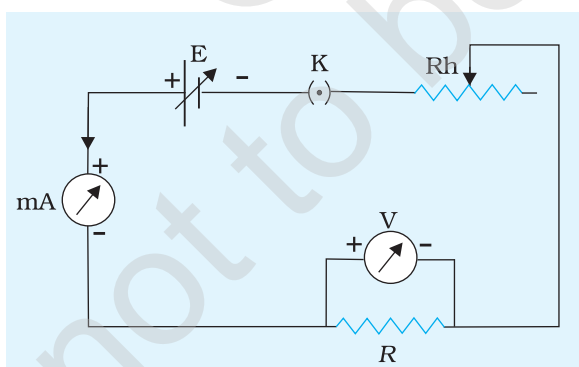

Fig. E 1.2 Circuit to find the relation between current I and potential difference, V for a given wire

3. Note whether pointers in milliammeter and voltmeter coincide with the zero mark on the measuring scale. If it is not so, adjust the pointer to coincide with the zero mark by adjusting the screw provided near the base of the needle using a screw driver.
4. Note the range and least count of the given voltmeter and milliammeter.
5. Insert the key K and slide the rheostat contact to one of its extreme ends, so that current passing through the resistance wire is minimum.
6. Note the milliammeter and voltmeter readings.

- Remove the key K and allow the wire to cool, if heated. Again insert the key. Shift the rheostat contact slightly to increase the applied voltage. Note the milliammeter and voltmeter reading.
- Repeat step 7 for four different settings of the rheostat. Record your observations in a tabular form.

OBSERVATIONS

- Range of ammeter = 0 ... mA to ...mA
- Least count of ammeter = ... mA
- Range of voltmeter = 0 ... V to ...V
- Least count of voltmeter = ...V
- Least count of metre scale = ... m
- Length of the given wire, $l = \dots\text{m}$

Table E 1.1: Voltmeter and milliammeter readings

Sl. No.	Applied potential difference [voltmeter reading V (V)]	Current flowing through the wire [milliammeter reading I (mA)]
	V	I
1		
2		
--		
6		

CALCULATIONS

- Plot a graph between the potential difference across the wire (V) and the current (I) flowing through it as shown in Fig. E 1.1.
- Determine the slope of the graph. The resistance of the given wire is then equal to the reciprocal of the slope.

From the graph $R = \frac{BC}{AB} \dots \Omega$

- Resistance per unit length of given wire = $\frac{R}{l} = \dots \Omega \text{ m}^{-1}$

Error

$$\frac{R}{R} = \frac{V}{V} = \frac{I}{I} = \dots$$

(E 1.4)

Here, R is resistance per unit length and ΔR is estimated error. ΔV and ΔI are the least count of the voltmeter and milliammeter respectively.

RESULT

1. The potential difference across the given wire varies linearly with the current.
2. The resistance per unit length of the wire is $(R \pm \Delta R)$ = (... .. Ωm^{-1}).

PRECAUTIONS

1. The voltmeter should be connected in parallel and the ammeter in series with the circuit. It should be ensured that current enters at the positive terminal and leaves at the negative terminal.
2. The key should be inserted only while taking observations, as excessive flow of current causes unnecessary heating of the wire.
3. Zero error in measuring instruments (voltmeter, ammeter, metre scale) must be taken cognizance of and should be eliminated in case of ammeter and voltmeter by adjusting the pointer with the help of the screw provided at the base of the needle, using a screw driver.

SOURCES OF ERROR

1. The wire used may not be of uniform area of cross-section.
2. The length of the resistance wire measured should be between one terminal of voltmeter and the other. The lengths of ends wound around the terminals of voltmeter, if included, would give error in measured length.

DISCUSSION

A resistor obeys Ohm's law. However, not all conducting devices obey Ohm's law e.g. diode, thyristor etc. These are called non-ohmic resistances.

SELF ASSESSMENT

1. A voltmeter is always connected in parallel and an ammeter in series with the circuit. Why? Will they record the respective parameters if connected in opposite manner?

- Why are copper wires normally used for connecting different components in an electric circuit?
- What happens if the current is allowed to flow through the circuit continuously for a long time? Why?

SUGGESTED ADDITIONAL EXPERIMENTS/ACTIVITIES

- Study the effect of length of wire on its resistance when its diameter is kept constant.
- Study the effect of diameter of wire on its resistance when its length is kept constant by using different SWG (standard wire gauge) wires available in the market.
- Study the resistivity of wires made up of different materials. Is the resistivity of all wires same?
- Two uniform wires of the same material have the same length. One has circular cross section of area A while the other is not circular but has the same area of cross section A . Will their resistances be equal?
- Study the voltage current relationship for the filament of a torch bulb.
- Set up a circuit as shown in Fig. E 1.3.

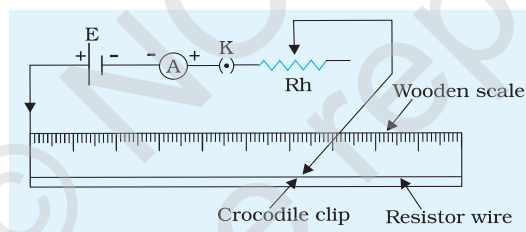

Fig. E 1.3

Note the ammeter reading I by connecting the crocodile clip at 10, 20, 30 cm length of wire. Plot a graph between $1/I$ and l . Find its slope and interpret its result. Can you use the graph to check the homogeneity of the resistance wire?

- Four resistances R_1 , R_2 , R_3 and R_4 are connected together as shown in Fig. E 1.4. Complete the electric circuit by connecting the combination of resistances to a 6 V source, an ammeter and a voltmeter. Explain, how would you measure current/voltage flowing through each one of the resistors.

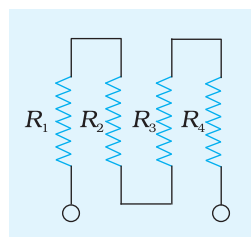

Fig. E 1.4

EXPERIMENT 2

AIM

To determine the resistance of a given wire using a metre bridge and hence determine the resistivity of the material of the wire.

APPARATUS AND MATERIAL REQUIRED

Metre bridge, a wire about 1m long (of material whose specific resistance is to be determined), a resistance box, a rheostat, galvanometer, a jockey, one-way key, a cell or battery eliminator, thick connecting wires, sand paper, screw gauge.

DESCRIPTION OF APPARATUS

Metre bridge

It consists of one metre long constantan wire AC of uniform cross-sectional area mounted on a wooden board with a scale (Fig. E 2.1). The two ends of the wire are attached to terminals A and C. Thick metal strips bent at right angles are used to provide two gaps E and F to connect resistors forming a Wheatstone's

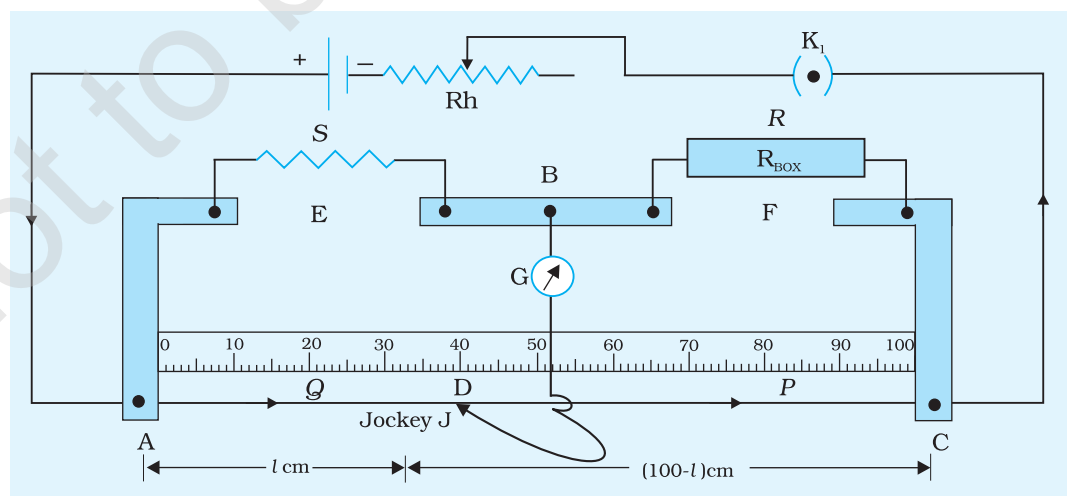

Fig. E 2.1 A metre bridge

bridge (Fig. E 2.2). The terminal B between the gaps is used for connecting galvanometer and other end of the galvanometer is connected to a jockey J.

PRINCIPLE

A metre bridge works on the principle of Wheatstone's bridge. As shown in Fig. E 2.2, it consists of four resistors **P**, **Q**, **R** and **S** connected in the form of a network ABCD. The terminals A and C are connected to two terminals of a cell through a key K_1 . Terminals B and D are connected to a sensitive galvanometer G through a key K_2 .

If there is no deflection in the galvanometer G, then balance condition for Wheatstone's bridge is

$$\frac{P}{Q} = \frac{R}{S} \quad \text{(E 2.1)}$$

We use this relation (E 2.1) to determine **S** if **P**, **Q** and **R** are known.

The unknown resistance **S** is connected in the gap E and a resistance box (R_{Box}) in gap F of the metre bridge. The terminal B is connected to one terminal of the galvanometer G. The other terminal of the galvanometer is connected to a jockey J which slides along the wire AC. A source of dc current is connected between A and C through a key K_1 so as to provide a constant potential drop along AC (Fig. E 2.1).

A resistor (or wire) of known resistance is inserted in the gap F by taking out corresponding key from the resistance box R_{Box} . The jockey is moved on the wire AC to obtain a condition of no-deflection in the galvanometer. It happens when the jockey is kept at a point D called the null point. In this condition;

$$\frac{P}{Q} = \frac{R}{S} = \frac{\text{Resistance of wire of length DC}}{\text{Resistance of wire of length AD}} \quad \text{(E 2.2)}$$

Unknown resistance **S** of the wire, having uniform cross-sectional area, is then given by

$$S = R \frac{l}{100 - l} \quad \text{(E 2.3)}$$

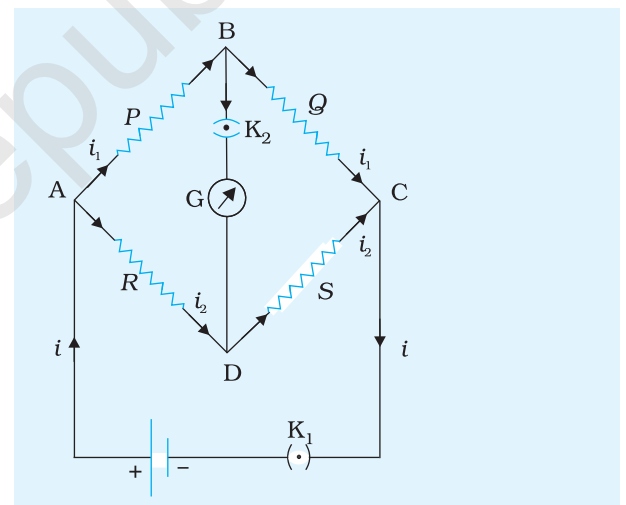

Fig.E 2.2 The Wheatstone's bridge

Because, for a wire of uniform cross-sectional area, resistance is proportional to length.

Thus, knowing l and R , and using Eq. (E 2.3), the unknown resistance S can be determined.

Resistivity

The specific resistance or resistivity ρ of the material of the given wire is

where S is the resistance of the wire of length L and $a = \pi r^2$, (r being the radius) is the area of cross-section.

P ROCEDURE

1. Find the average diameter of the wire with a screw gauge. From this, obtain the value of its radius r .
2. Clean the insulation at the ends of connecting wires with a piece of sand paper. Tighten all plugs of the resistance box (R_{BOX}) by pressing each plug.
3. Set up the circuit as shown in Fig. E 2.1 with unknown resistance wire of known length in gap E.
4. Next, introduce some resistance R in the circuit from the resistance box. Bring the jockey J in contact with terminal A first and then with terminal C. Note the direction in which pointer of the galvanometer gets deflected in each case. Make sure that jockey remains in contact with the wire for a fraction of a second. If the galvanometer shows deflection on both sides of its zero mark for these two points of contact of the jockey, null point will be somewhere on the wire AC. If it is not so, adjust resistance R so that the null point is somewhere in the middle of the wire AC, say, between 30 cm and 70 cm.
5. If there is one-sided deflection, check the circuit again, especially junctions, for their continuity.
6. Repeat step 4 for four different values of resistance R .
7. Interchange the position of the resistances S and R and repeat steps 4 to 6 for the same five values of R . While interchanging S and R , ensure that the same length of wire of resistance S is now in the gap F. The interchange takes care of unaccounted resistance offered by terminals.

OBSERVATIONS

1. Length of the wire of unknown resistance, $L = \dots \text{cm}$
2. Measurement of diameter of wire of unknown resistance

Least count of the screw gauge (L.C.) = ... mm

Zero error of the screw gauge = ... mm

Zero correction of the screw gauge = ... mm

Table E 2.1: Diameter of Wire

Sl. No.	Reading along one direction			Reading along mutually perpendicular direction			Mean Diameter
	Main scale reading p (mm)	Coinciding circular scale division n	Diameter $d_1 = p + n \text{ L.C.}$ (mm)	Main scale reading p' (mm)	Coinciding circular scale division n'	Diameter $d_2 = p' + n' \text{ L.C.}$ (mm)	
							$d = \frac{d_1 + d_2}{2}$ (mm)
1							
2							
3							

Mean diameter (corrected for zero error) = ... mm

Radius of wire $r = \dots \text{mm}$

Table E 2.2: Unknown resistance

Sl. No.	S in the left gap				S in the right gap				Mean resistance	ρ $\Omega \text{ m}$	ΔS_1 Ω	ΔS_2 Ω	ΔS Ω	Δp $\Omega \text{ m}$
	Resistance R Ω (ohm)	Position of balance point D (cm)	Balancing length AD l (cm)	Length DC = $100 - l$ (cm)	Position of balance point D' (cm)	Balancing length AD' = l' (cm)	Length D'C' = $100 - l'$ (cm)	$100 \frac{l}{l'}$ (ohm)						
1														
2														
...														
5														

Mean

CALCULATIONS

$$L = \dots \text{ cm} \quad r = \dots \text{ mm} \quad S = \dots \Omega$$

Substituting these values in $\rho = S \frac{\pi r^2}{L}$, calculate the value of ρ in ohm-m.

Error

$$(E 2.4) \quad \frac{S}{S} \frac{2r}{r} \frac{L}{L}$$

Errors Δr , ΔL are the least counts of the measuring instruments and error ΔS is the maximum of the values obtained by following equations :

$$(E 2.5) \quad S_1 \frac{l}{l} \frac{l}{100 l} S_1$$

$$(E 2.6) \quad S_2 \frac{l}{l} \frac{l}{100 l} S_2$$

If it is presumed that resistance offered by the resistance box is the same as that indicated on it, then $\Delta R = 0$

Therefore, maximum error is $\Delta S = \Delta S_1 + \Delta S_2$

RESULT

- The unknown resistance of the given wire is found to be $S + \Delta S = \dots \dots \Omega$
- The resistivity of the material of the wire is $\rho \pm \Delta \rho = \dots \dots \Omega \text{ m}$
Here S and ρ are mean values. ΔS and $\Delta \rho$ are maximum of the five values of error.

PRECAUTIONS

- All the connections and plugs should be tight.
- Jockey should be moved gently over the metre bridge wire.
- The plug in the key (K_1) should be inserted only at the time of taking observations.
- Null points should be in the middle of the wire (30 cm to 70 cm).

SOURCES OF ERROR

1. The metre bridge wire may not be of uniform area of cross-section.
2. Effect of end resistances due to copper strips, connecting screws, may affect the measurement.
3. The length L of the wire should not include the lengths below the terminals when placed in gap E or F.
4. The resistances of end pieces/metal strips may not be negligible. The error introduced by it can be reduced by interchanging the known and unknown resistances in gaps E and F.
5. The length measurements l and l' may have error if the metre bridge wire is not taut and along the scale in the metre bridge.
6. Galvanometer pointer is expected to be at zero when no current flows through it. However, many times it is observed that it is not so. In such cases, pointer has to be adjusted to zero by gently moving the screw below the scale with the help of a screw driver. Otherwise null point must be obtained by tapping the jockey on the wire.

DISCUSSION

1. It is generally preferred that R and S combination should be so chosen that the balance point comes near the middle of the metre bridge wire. Why? Is the sensitivity of detecting balance point best when R and S have same order of resistance?
2. The accuracy with which the null point can be detected also depends upon the sensitivity of the galvanometer used. To investigate this, find the distance through which the jockey has to be moved to cause a just perceptible deflection of the galvanometer. How can the error due to this be minimised? Does it have something to do with the potential difference between A and C?
3. The length l , that is, the position of the jockey, may be read upto, 0.1 cm (say). How much uncertainty will be introduced in the result due to this error?
4. It is advised that key should be unplugged when readings are not being taken to avoid unnecessary heating of the wire. Why? In what way, will the heating affect the null point? Will it be significant?

SELF ASSESSMENT

1. The bridge wire may not be exactly 100 cm long, so record its exact length and use this in the calculation.
2. If the metre bridge wire is not of uniform area of cross section, how will it affect the observations?

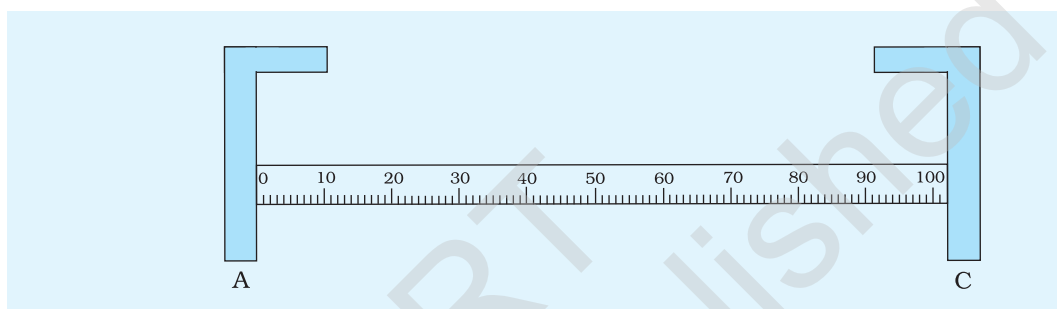

Fig. E 2.3 Defective scale of a metre bridge

3. If the metre bridge wire is not made of a material of uniform density, how will it affect the observations?
4. If the same experiment is performed with $AC = 50$ cm wire instead of 1 m, what changes would be there in the result?
5. The scale attached along the wire may not indicate the exact length as shown in Fig. E 2.3. How would you minimise the error?
6. Why is the metre bridge not suitable for measuring very high/very low resistances?
7. Why is the metre bridge preferred for determining the resistance of a wire over the Ohm's law circuit?

SUGGESTED ADDITIONAL EXPERIMENTS/ACTIVITIES

1. Determine the resistance of an electric bulb of given voltage and power. Attach crocodile clips at the end of two copper wires. Use these to connect the bulb in the gap E as shown in Fig. E 2.4. Why does the resistance obtained by you differ from the theoretical value?
2. Making use of your observations plot a graph between $(100 - l)/l$ and R . Find the slope of the graph. What does it represent?
3. The resistance of a wire changes with temperature. You may study this by using a metre bridge. You may use a beaker with mustard oil, a suitable thermometer (0-300°C) and resistance wire of known length. The experimental set-up shown in Fig. E 2.5 may be used.

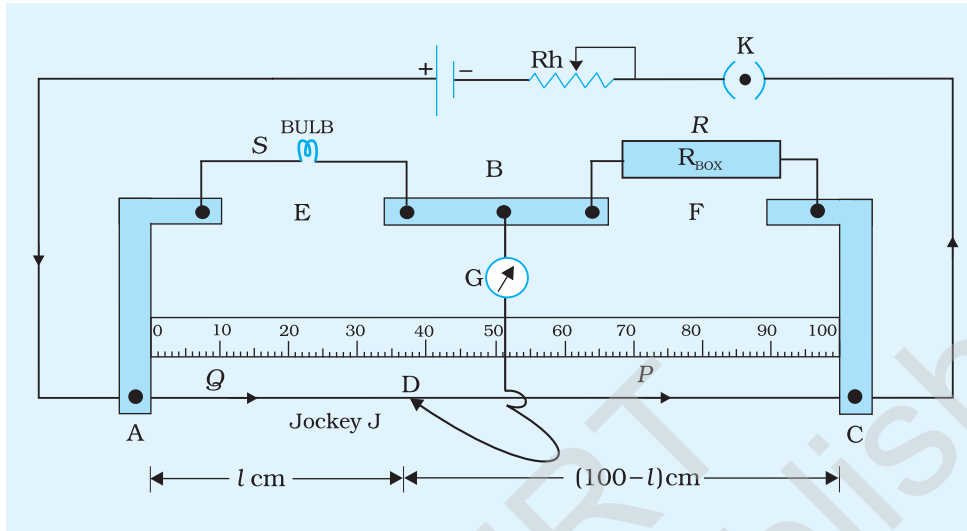

Fig. E 2.4

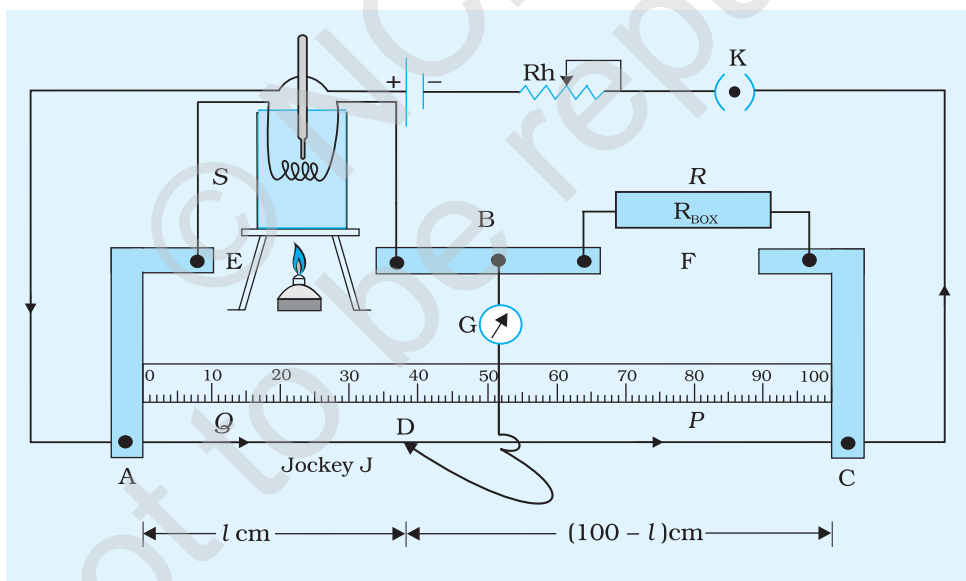

Fig. E 2.5